

Programmes After Market Services

NHE-8/9
CarKit Installation Guides

NHE-8 INSTALLATION INSTRUCTIONS

Contents

Introduction	3
General	3
Basic Car Kit (CARK-48)	4
Professional Car Kit (CARK-74)	5
Component Parts	6
Installation	9
Testing	12

Introduction

General

This installation guide has been prepared to provide the basic information necessary to install car kits. This guide is not intended to be definitive, because different types and models of vehicle will require different installation work. The information given is for general guidance only.

The terms of warranty demand that this car kit be installed by an experienced installation facility. An end user should never attempt to install this car kit without professional assistance as the installation requires special tools and knowledge.

Please refer to the telephone's user guide for instructions on the telephone's operation, care and maintenance, including important safety information.

Note: Read the warnings below before beginning the installation procedure.

WARNINGS

- 4 ENSURE THAT THE VEHICLE BATTERY IS DISCONNECTED BEFORE YOU START THE INSTALLATION PROCEDURE, AND THAT IT REMAINS DISCONNECTED DURING THE PROCEDURE.
 - 5 DO NOT SMOKE OR USE OPEN FLAMES WHEN WORKING NEAR THE VEHICLE'S FUEL SYSTEM.
 - 6 ENSURE THAT ELECTRICAL CABLES, HYDRAULIC LINES AND FUEL LINES ARE NOT DAMAGED DURING INSTALLATION.
 - 7 ENSURE THAT NORMAL CONTROL AND OPERATION OF THE VEHICLE IS NOT IMPAIRED BY THE INSTALLATION, PARTICULARLY THE BRAKES AND STEERING.
 - 8 ALTHOUGH ELECTRONIC SPEED CONTROL, ABS ANTI-LOCK BRAKE AND FUEL INJECTION SYSTEMS ARE RELATIVELY IMMUNE TO MALFUNCTION CAUSED BY NEARBY RADIO TRANSMISSIONS, SHOULD YOU EXPERIENCE FALSE OPERATION OF THESE SYSTEMS OR ARE IN ANY DOUBT WHATSOEVER AS TO THEIR FUNCTIONALITY, PLEASE CONSULT THE VEHICLE DEALER.
 - 9 THE CAR KIT IS SUITABLE FOR USE ONLY IN VEHICLES WITH A 11..32 V NEGATIVE GROUNDING. USE ON OTHER SUPPLY VOLTAGES OR ALTERNATIVE POLARITY WILL DAMAGE THE EQUIPMENT.
 - 10 THE PHONE SHOULD NOT BE LEFT SWITCHED ON FOR EXTENDED PERIODS WITHOUT RUNNING THE VEHICLE'S ENGINE. FAILURE TO COMPLY COULD DRAIN THE VEHICLE'S BATTERY.
-

Basic Car Kit (CARK-48)

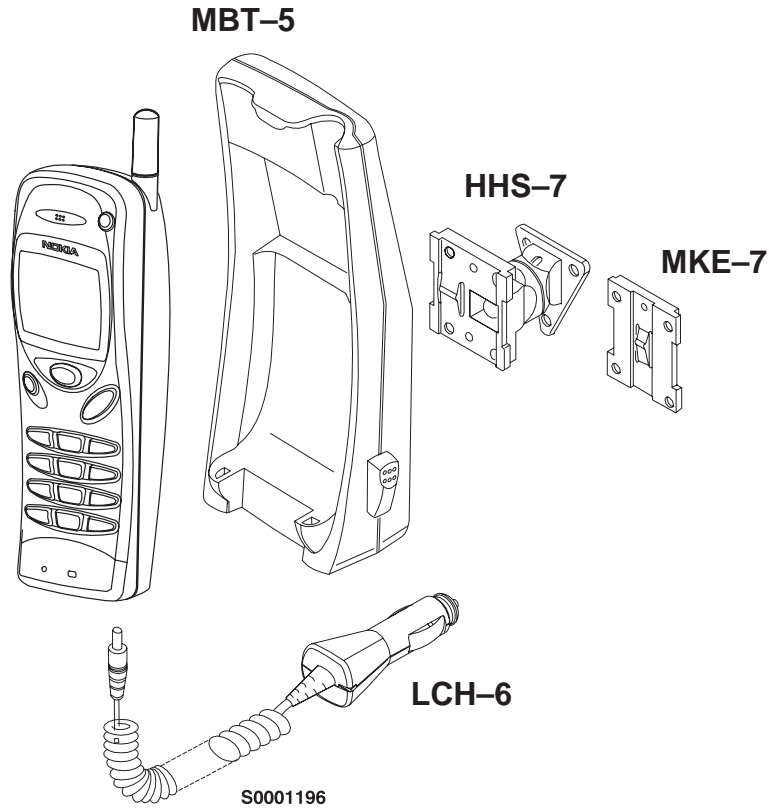

Product Name:	Type:	Code:
Phone Holder	MBT-5	0620030
Mounting Plate	MKE-7	065002
Swivel Mounting Plate	HHS-7	0650020
Universal Mobile Charger	LCH-6	0675076

Professional Car Kit (CARK-74)

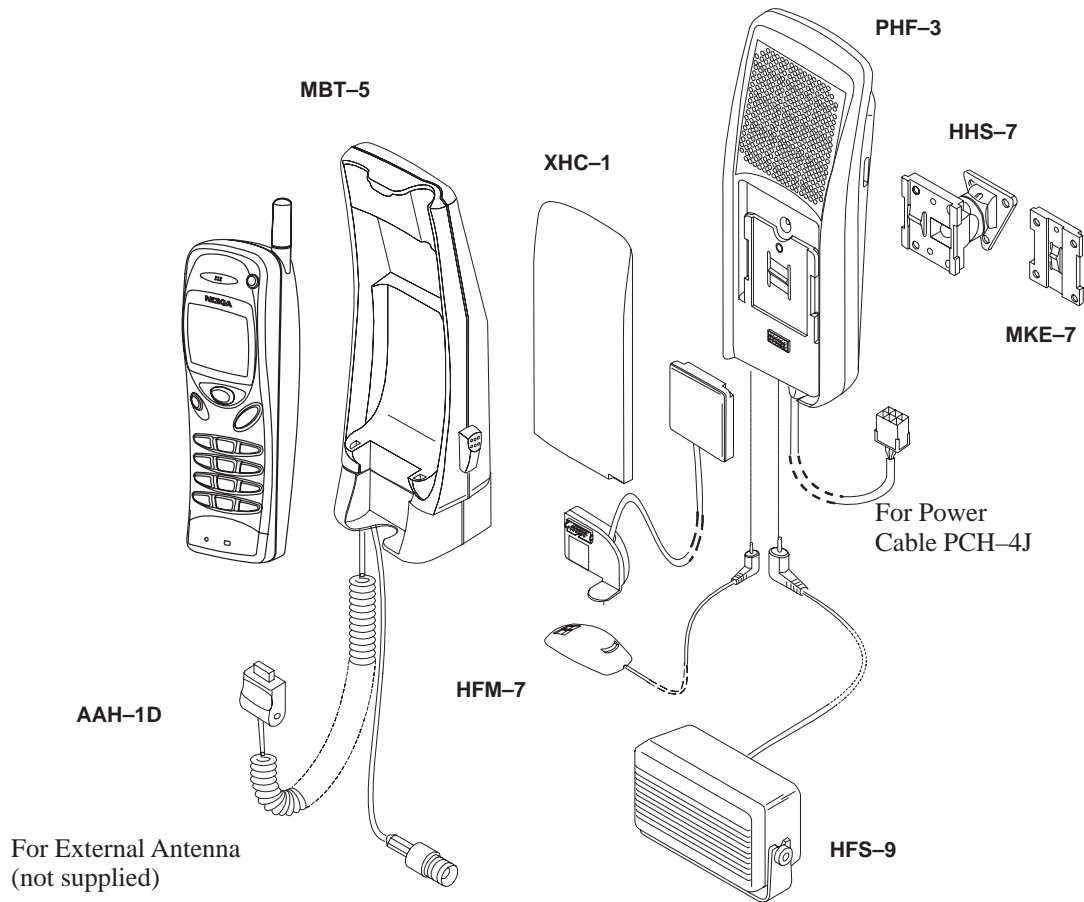

Product Name:	Type:	Code:
Phone Holder	MBT-5	0620030
Standard Handsfree Unit	PHF-3	0694030
Mounting Plate	MKE-7	0650021
Swivel Mounting Plate	HHS-7	0650020
Power Cable	PCH-4J	0730055
External Antenna Unit	AAH-1D	0750077
Handsfree Microphone	HFM-7	0690002
Handsfree Speaker	HFS-9	0690012
Extension Cable	XHC-1	0730060

Component Parts

Mounting Plate MKE-7 and Swivel Mounting Plate HHS-7

MKE-7 is a fixed position mounting plate; HHS-7 is a swivel mounting plate which allows for adjustable fixing. Both two mounting plates are interchangeable.

Phone Holder MBT-5

The phone holder allows the phone to be firmly located in a convenient position. The phone holder is attached to the vehicle's interior using mounting plate MKE-7 or alternatively swivel mounting plate HHS-7. The mounting must be secured with a screw (delivered with MKE-7/HHS-7).

Universal Mobile Charger LCH-6

The universal mobile charger enables the phone to be charged via the vehicle's cigarette lighter socket. The charger connects to the phone via a d.c. jack socket located on the base of phone. The supply voltage may vary between 11 and 32 V.

External Antenna Unit AAH-1D

The external antenna unit allows an external antenna to be connected to the phone's antenna when the phone is located in the mobile holder. The external antenna unit is fastened to the bottom of the phone holder as shown below.

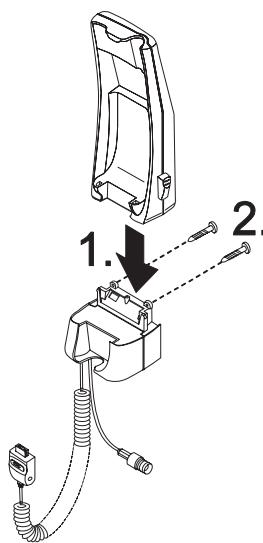

Power is supplied either from the vehicle's battery via the fixed mobile charger, LCM-1 or from the cigarette lighter socket via the universal mobile charger, LCH-6 (not supplied).

Fixed Mobile Charger LCM-1

The fixed mobile charger provides a power supply for the external antenna unit and the mobile phone.

Output Power Cable PCC-2

The output power cable connects the fixed mobile charger to the external antenna unit.

Power Cable PCM-5

The power cable connects the fixed mobile charger, LCM-1, to the vehicle's power supply. The red wire must be connected to the + voltage supply controlled by the vehicle's ignition key via the supplied fused connector. The black wire must be attached to a good negative GND connection.

Standard Handsfree Unit PHF-3

The standard handsfree unit enables the phone to operate in handsfree mode. The unit is attached to the vehicle interior using mounting plate MKE-7, or swivel mounting plate HHS-7. The mounting must be secured with a screw (delivered with MKE-7/HHS-7). A temporary installation can be achieved using installation belts (not supplied).

Power is supplied from the vehicle's battery via the power cable PCH-4J. The standard handsfree unit provides the power supply to the phone via the system connector.

The HF microphone, HFM-7, connects to the MIC socket. The phone holder can be attached to the standard handsfree unit as shown.

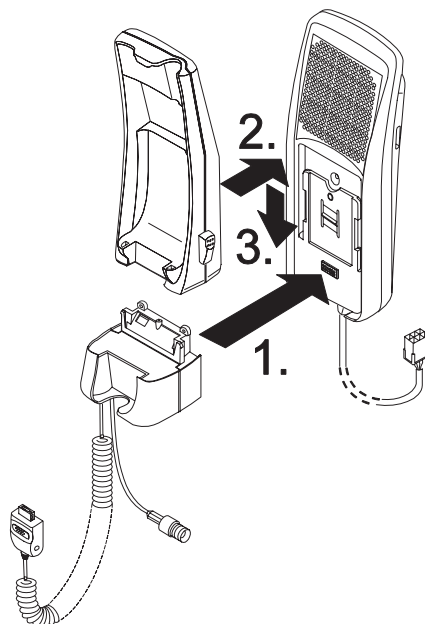

Power Cable PCH-4J

The power cable connects the standard handsfree unit, PHF-3, to the vehicle's power supply. The red wire must be connected to the + voltage on the vehicle's battery via the supplied fused connector. The black wire must be attached to a good negative GND connection.

The blue ignition sense (IGNS) wire is connected to +12 V voltage controlled by the vehicle's ignition key via the supplied fused connector. See section "Ignition Sense".

The yellow wire is used for car radio muting (XCRM). The line goes down to 0 volts during a call. See section "Car Radio Muting".

The green wire is used for motor antenna (AMC). The voltage in this output is +12 V whenever the phone is on. See section "Antenna Motor Control".

Handsfree Microphone HFM-7

The HF microphone connects directly to the standard handsfree unit (to MIC socket).

Extension Cable XHC-1 (optional for PHF-3)

The extension cable allows a phone holder and an external antenna unit together to be connected to the standard handsfree unit when the unit is located on the place apart from the others. Ensure PHF-3 is located so that the incoming voice from the internal speaker is loud enough.

External Mobile Antenna (not supplied)

The external antenna unit is designed to operate with a high quality external antenna. However, due to many different types of antennas being available, an antenna is NOT included as part of this kit. Please, consult the dealer to find out which is the most suitable antenna type for your installation.

Installation

There are some important aspects that require special attention in positioning car kit accessories.

The positioning of the phone holder is the most important factor when trying to achieve the most comfortable position for the user. The location of the holder should be selected so that the visibility of the phone's display is good under all lighting conditions, but not so that the driver's attention is easily distracted. The holder should be located so that the driver can easily reach the keypad. Under no circumstances should the holder prevent the driver from controlling or operating the vehicle in any way or observing traffic.

The fixed mobile charger can be installed in a hidden location, since there is no need to disconnect cables during normal operation. Ensure the location does not subject the unit and cables to moisture or mechanical pressure. Also remember clean the mounting tape location properly before installing.

The handsfree microphone can be installed on the driver's sunvisor or the A-pillar. Ensure the microphone is as close to the driver's mouth as possible, and attached to a surface that is mechanically quiet. The microphone should be mounted at least 3 ft/1 m away from the handsfree unit speaker to avoid acoustic feedback. See separate microphone installation guide.

Ensure cables are routed as far away as possible from the vehicle's electronic systems (refer to WARNINGS). Also ensure cables are not subjected to undue mechanical stress e.g. under seats or against sharp edges. The external antenna adapter should always be connected to the antenna via a non-radiating cable (e.g. coax).

The most important component of the installation is the antenna. The location of the antenna as well the quality of the antenna and its installation have a considerable influence to the overall performance of the whole system. Therefore it is necessary to emphasize some aspects, which too often have caused unnecessary service work.

The best place for the antenna is the rooftop. The overall performance of a rooftop antenna is clearly superior to any other antenna type or location. The Antenna shall be mounted in a position such that no part of human body will normally rest too close to any part of the antenna unless there is an intervening metallic screen, for example, the metallic roof.

- highest place in the car
- proper ground place
- omnidirectional radiation pattern
- minimum risk for disturbances
- user safety

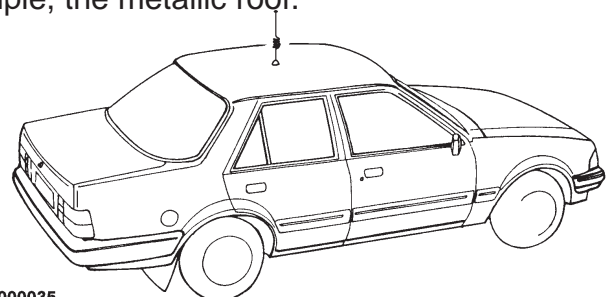

S0000035

After drilling the hole for the antenna remember to clean the hole from the drilling swarf, so that surface is even. This is needed in order to ensure proper and reliable connection between the ground plane and the antenna. After cleaning it is advised to apply some rust-proofing compound to the hole.

Mount the base of the antenna tightly to its place. Consult the antennas manuals for determining the maximum bending angle before attempting any bending operation.

To avoid drilling a hole in the vehicle's bodywork, a glass-mounted antenna can be chosen and located on the rear window of the vehicle.

Try to route the antenna cable so that possible sources of disturbances are avoided, as well anti-skid brake systems. The shorter the antenna cable, the smaller the attenuation, and the better the performance of the antenna. The antenna coupler should always be connected to the antenna via a non-radiating cable (e.g. coax).

Most of the antennas today have adapted the minigrimp connector system which eliminates the need for special grimping tools and connectors. If however the purchased antenna has traditional connectors, use only proper connectors and tools. The antenna coupler uses TNC-female type antenna connector for reasons of reliability and attenuation.

Ignition Sense IGNS

The ignition sense feature prevents your car kit from draining the car battery by executing an auto power off in 20 seconds after the ignition key has been turned off. The blue wire of the power cable is used for the ignition sense feature. The use of ignition sense is recommended to prevent accidental draining of the car's battery. The wire is connected via a 1 A fuse to a 12/24 volt potential that is controlled by the ignition key. Do not connect it directly to the high voltage sections of the ignition circuit.

Car Radio Muting CRM

The car kit offers a feature that can mute the car radio automatically during a conversation. This feature is convenient and provides for safer handsfree operation. The car radio muting feature is based on a grounded line, so it means that in standby, the yellow wire (XCRM) is not grounded and car radio works normally, but during a call, line is grounded and car radio is muted. Note that an auxiliary relay or muting unit must be used when the car radio doesn't have a mute feature available.

When a relay is used, connect in series with the car radio main supply. A 200 mA fuse should be used to protect the XCRM output in event of a short circuit. Some radios have separate supplies for amplifiers and motors, and another for memory backup purposes.

Very often these radios also have a secret code system, which activates itself if a break in the memory supply is detected. Be careful when installing the relay not to break the memory supply (usually marked ACC or +MEM), but to install the relay in the main supply feed.

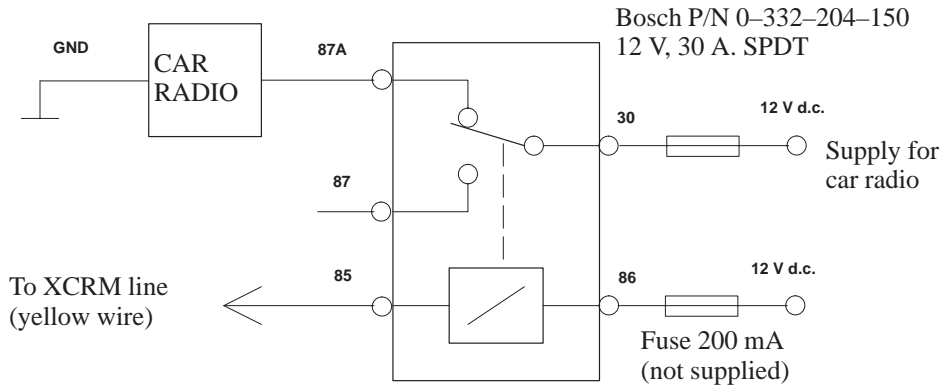

Another possibility is to use a special muting unit, which mutes the radio by connecting load resistors to the speaker lines of the car radio.

Antenna Motor Control AMC

The antenna motor control offers a feature, green wire of the system cable (AMC), that may be used to control different devices on and off. The voltage in this output is +12 V whenever the phone is on. If the phone is turned off, the voltage disappears. The maximum output current is 200 mA, therefore for example motorized antenna must be controlled via a relay, see picture below.

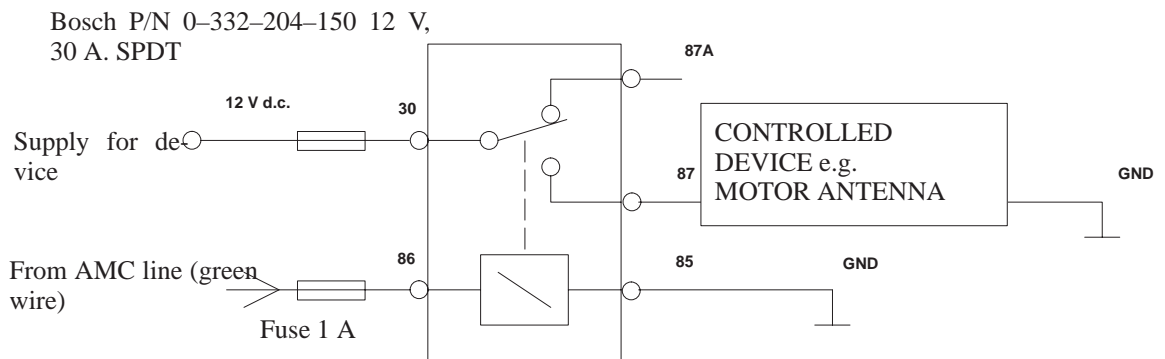

All installations should take into account any special requirements of the customer. However, should the customer require an installation that is illegal or unsafe these facts must be pointed out to the customer and a policy of non-compliance adopted.

Testing

Once installed, the equipment should be tested to ensure that it is operating satisfactorily and that the position of the units does not impair on the driver's ability to control and operate the vehicle in any way.

Use the phone to make a call when the vehicle is parked with the engine running. During the call, switch off the engine. Ensure that the phone is operational with the engine running and with the engine switched off. For operating information refer to the 'Owner's Manual' supplied with the phone.